



Specification Information

Product Code: 1186-G

Product Name: Wall Protector Plate

Individual Carton UPC: 624622118617

Individual Carton Shipping Dimensions: 99.0cm L x 50.8cm W x 5.1cm H (39"L x 20"W x 2"H)

Individual Carton Shipping Weight: 3.6kg (8.0 lbs)

Site Location: Frost 1186-G wall protector plate is designed for use under hand dryers to guard the wall from excess water. These wall protectors can be used for other applications as well. They are most commonly used in high traffic areas such as; Schools/Universities, Hospitals, Recreation Centres, Fitness Facilities, Cinemas, Restaurants, and Airports.

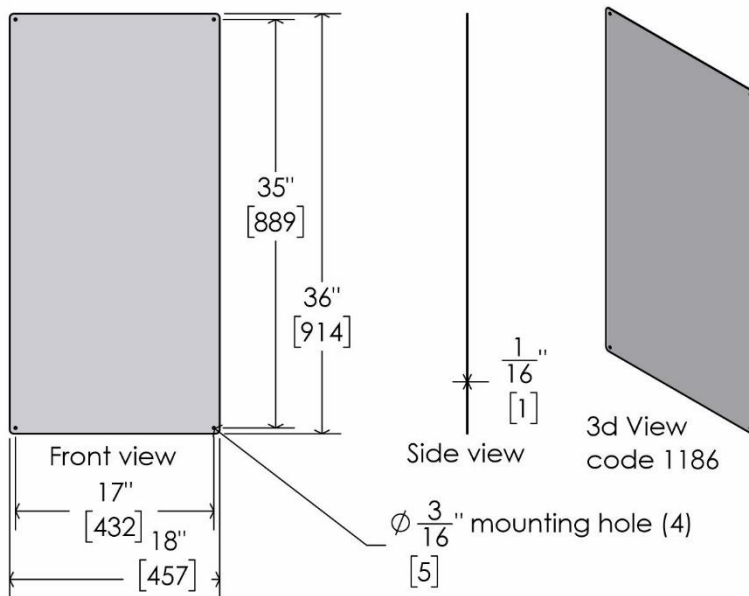

Features:

- Constructed of 20-gauge steel with power coated grey finish
- Frameless one-piece panel can be easily wiped clean
- Protects wall surfaces from damage
- Light grey epoxy finish helps conceal water marks
- Comes with pre-drilled mounting holes
- Can be mounted with double-sided adhesive tape also (not included)
- Able to be mounted vertically or horizontally
- Canadian made

Materials:

- 20 gauge cold rolled steel
- Grey epoxy powder coat finish

Product Dimensions:

- 45.7cm L x 91.4cm H x 0.15cm D (18"L x 36"H x 0.0625"D)

Product Weight:

- 3.2 kg (7.0 lbs)

Frost Products Ltd

5276 John Lucas Drive
Burlington, ON, Canada, L7L5Z9

(905) 332-5700
1-800 667-5094

info@frostproductsltd.com
www.Frostproductsltd.com



Specification Information

Installation Guidelines:

Mounting location may vary depending on existing hand dryer configuration, size, installation, and other site requirements. Please note that it is recommended that all installations be conducted by a qualified tradesperson. Failure to do so may result in serious injury. Mounting hardware is not included. The tradesperson is responsible for determining the appropriate mounting method based on the site's requirements. Please read and follow any additional installation guidelines provided with the product if applicable.

Maintenance:

Normal preventative maintenance and cleaning will keep Frost products functioning properly and may extend normal product life. Products should be wiped down with a damp soft cloth periodically. Do not use harsh detergents or chemical cleaners. For general dirt and blemishes on painted steel, use warm water and mild soap, or a general mild cleaning solution. When using any type of cleaning solution, spray onto a discrete area to test before full usage. After the cleaning agent is applied, wipe off with a clean soft cloth or sponge.

Warranty:

If any product or part proves to be defective within 12 months from the date of shipment from the factory it will be repaired or replaced without any charge, including freight costs when authorized. Costs resulting from the installation or removal of defective products are not covered under this warranty.