



Specification Information

Product Code: 1001-BLK- Series

Product Name: Stainless Steel 1.5" Diameter Grab Bars

Individual Carton UPC:

1001-BLK-18" – 624622016203

1001-BLK-24" – 624622016302

1001-BLK-30" – 624622012410

1001-BLK-36" – 624622016500

1001-BLK-42" – 624622016609

Individual Carton Shipping Dimensions:

1001-BLK-18" – 32" L x 7.5" D x 5" H (81.3cm L x 19.1cm D x 12.7cm H)

1001-BLK-24" – 32" L x 7.5" D x 5" H (81.3cm L x 19.1cm D x 12.7cm H)

1001-BLK-30" – 32" L x 7.5" D x 5" H (81.3cm L x 19.1cm D x 12.7cm H)

1001-BLK-36" – 37" L x 3" D x 3.25" H (94.0cm L x 19.1cm D x 12.7cm H)

1001-BLK-42" – 43" L x 3" D x 3.25" H (109.2cm L x 19.1cm D x 12.7cm H)

Individual Carton Shipping Weight:

1001-BLK-18" – 1.75lbs (0.8kg)

1001-BLK-24" – 2.25lbs (1.0kg)

1001-BLK-30" – 2.75lbs (1.2kg)

1001-BLK-36" – 3.25lbs (1.5kg)

1001-BLK-42" – 4.00lbs (1.8kg)

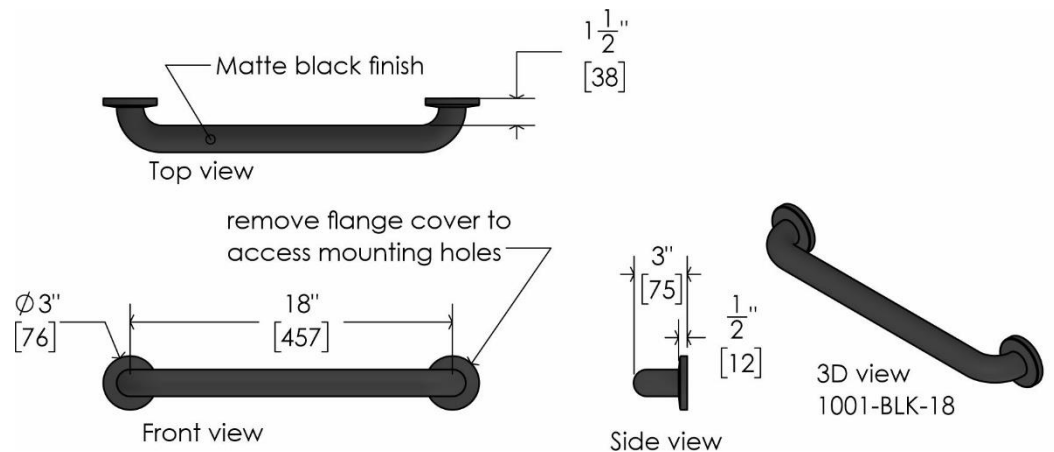

Site Location: Frost's 1001-BLK- series stainless steel grab bars offer an antimicrobial matte black finish. These grab bars have a 1-1/2" diameter. Typically, these units are used in schools/universities, nursing homes, hotels, restaurants, malls, office buildings, condominiums, hospitals, recreation centres, and residential properties. The durable construction and high quality stainless steel make this unit a popular choice. The Frost BLK grab bar series comply with handicap codes requiring 1-1/2" bar diameter and wall clearance of 1-1/2". Barrier free access specifications may vary depending on jurisdiction.

Features:

- Stainless steel
- Antimicrobial matte black finish
- Easy to install snap on flanges with concealed mounting
- Come in a variety of lengths

Materials:

- Snap flange is 12 gauge stainless steel with a full 360 degree bead weld to the 18 gauge stainless tubing. 1-1/2" dia. stainless steel, type 304, matte black finish.

Frost Products Ltd

5276 John Lucas Drive
Burlington, ON, Canada, L7L5Z9

(905) 332-5700
1-800 667-5094

info@frostproductsltd.com
www.frostproductsltd.com



Specification Information

Strength and Installation Warning: Frost grab bars that provide 1-1/2" (38mm) clearance from wall can support loads in excess of 900 pounds (408kg) if properly installed. Other grab bar configurations can support loads in excess of 250 pounds (113kg) if properly installed, complying with accessible design for structural strength. All grab bars must be installed by qualified trades persons. Installers must consult and comply with local building codes. Mounting hardware and other systems to be determined by contractor and installer pending specific structure, design, and conditions. All installations must be fully inspected and approved by property owners and maintenance personnel prior to bar being put into use. Failure to comply to proper installation procedure will void warranty and may result in malfunctioning or injury.

Product Dimensions:

1001-BLK-18" – 18" L x 3" D x 3.25" H (45.7cm L x 7.6cm D x 8.3cm H)
1001-BLK-24" – 24" L x 3" D x 3.25" H (61.0cm L x 7.6cm D x 8.3cm H)
1001-BLK-30" – 30" L x 3" D x 3.25" H (76.2cm L x 7.6cm D x 8.3cm H)
1001-BLK-36" – 36" L x 3" D x 3.25" H (91.4cm L x 7.6cm D x 8.3cm H)
1001-BLK-42" – 42" L x 3" D x 3.25" H (106.7cm L x 7.6cm D x 8.3cm H)

Product Weight:

1001-BLK-18" – 1.5lbs (0.68kg)
1001-BLK-24" – 2lbs (0.9kg)
1001-BLK-30" – 2.5lbs (1.13kg)
1001-BLK-36" – 3lbs (1.3kg)
1001-BLK-42" – 3.5lbs (1.6kg)

Installation Guidelines: All grab bars must be installed by qualified trades persons. Installers must consult and comply with local building codes. Mounting hardware and other systems to be determined by contractor and installer pending specific structure, design, and conditions. All installations must be fully inspected and approved by property owners and maintenance personnel prior to bar being put into use. Failure to comply to proper installation procedure will void warranty and may result in malfunctioning or injury.

Maintenance: Normal preventative maintenance and cleaning will keep Frost products functioning properly and may extend normal product life. Products should be wiped down with a damp soft cloth periodically. Approved stainless steel cleaner may be used to clean scuffs or fingerprints on stainless surfaces. Do not use harsh detergents or chemical cleaners. For stainless steel please do not spray with any product containing bleach, acids, or chlorides, which can be found in many cleaning products such as toilet bowl cleaners. Use of these cleaning solutions may cause discoloration and if used for prolonged periods of time they can eat away at points in the stainless steel. If discoloration occurs, the use of an approved stainless steel cleaner and a firmer scrub pad, such as a Scotch Brite Pad #7447, may remove the markings. Wipe away any debris from the area and gently rub with the pad. Then spray the area with a stainless steel cleaner/polish and rinse and dry. Always wipe with the grain direction for stainless steel products. If a cleaning agent has begun to eat away at the steel on a unit then the unit will likely need to be replaced. The stainless steel that Frost Products uses is of high quality and stainless steel is resistant to rust. However, discoloration that appears to be rust can be caused by cleaning solutions and soaps mentioned above. It is important to discontinue use of any cleaning agent or soap if discoloration begins to occur. Clean off the discoloration as quickly as possible to avoid any permanent damage to the unit. Maintenance staff should be taught how to recognize the signs that they are not using the appropriate cleaning products and how to correctly maintain stainless steel items.

Frost Products Ltd

5276 John Lucas Drive
Burlington, ON, Canada, L7L5Z9

(905) 332-5700
1-800 667-5094

info@frostproductsltd.com
www.frostproductsltd.com



Specification Information

Warranty: If any product or part proves to be defective within 12 months from date of shipment from the factory it will be repaired or replaced without any charge including freight costs when authorized. Costs resulting from the installation or removal of defective products are not covered under this warranty. Discolouration to stainless steel parts resulting from exposure to harsh environmental and / or chemicals are not considered to be defects in workmanship or material and are not covered under warranty.