



# Specification Information

**Product Code:** 717

**Product Name:** Universal Automatic Foam Soap/Sanitizer Dispenser

**Individual Carton UPC:** 624622717001

**Individual Carton Shipping Dimensions:** 15.2cm H x 30.5cm W x 15.2cm D (6" H x 12" W x 6" D)

**Individual Carton Shipping Weight:** 1.3 kg (3.0 lbs)

**Site Location:** Frost's 717 universal automatic foam soap/sanitizer dispenser offers a durable and professional option for areas requiring a hands-free solution. Typically, the dispenser is used in schools/universities, airports, restaurants, malls, hospitals, long term care facilities, airports, office buildings, condominiums, fitness facilities, and recreation centres. This product will quietly and automatically dispense foam soap/sanitizer when a hand is placed within 6cm (2 ¼") from the sensor.

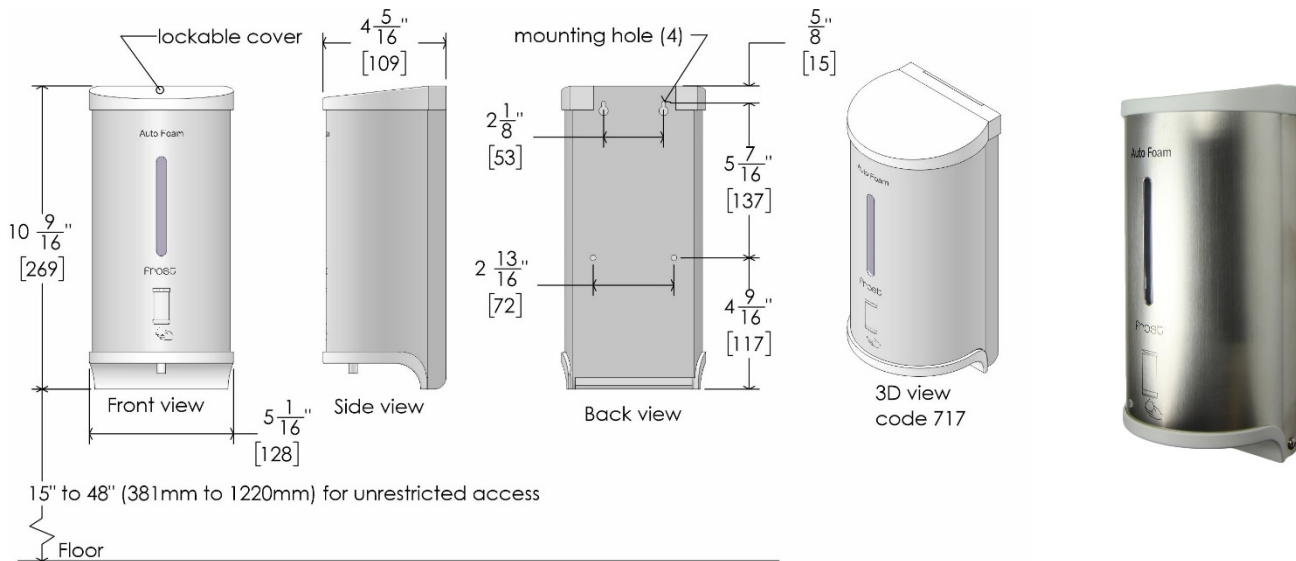

## Features:

- Can be wall, mirror, or stand mounted
- Non-proprietary dispenser which can lead to cost savings for end users and property managers
- Bulk filled refillable soap/sanitizer reservoir
- Powered by 4 "AA" alkaline batteries (not included)
- Battery life is 1 year or 20,000 uses
- Low battery indicator light
- Lockable
- Easy to clean and maintain

**Dispensing:** Soap/sanitizer is dispensed when hand is placed within 6cm (2 ¼") under the unit. Foam quantity dispensed: 0.7-0.8 cc. A low battery indicator light will flash blue when the batteries are near their end.

## Capacity:

- This dispenser has an 800 ml (27.1 US fl oz) capacity

## Materials:

- Front: Stainless steel, brushed finish
- Top/Bottom: Plastic

Frost Products Ltd

5276 John Lucas Drive  
Burlington, ON, Canada, L7L5Z9

(905) 332-5700  
1-800 667-5094

info@frostproductsltd.com  
www.frostproductsltd.com



# Specification Information

- Dispensing Nozzel: Plastic
- Viewing Window: Lucite

## Product Dimensions:

- 26.9cm H x 12.9cm W x 10.9cm D (10.6" H x 5.1" W x 4.3" D)

## Product Weight:

- 0.9 kg (2 lbs)

**Installation Guidelines:** For unrestricted access, bottom of the unit to floor must be between 38.1cm to 121.9cm (15" to 48"). This dispenser comes with four standard combination style screws and anchors. The product also comes with adhesive pads for mirror mounting. Mark mounting holes against the mounting surface using a pencil and level. Drill four holes with a 5/16" diameter and insert anchors. Insert two screws into the top anchors and hang the soap dispenser onto them. Remove soap reservoir and attach remain two screws. For mirror mounting, attach adhesive pad to back of the unit. Using level, carefully push soap dispenser to mirror. Please note that it is recommended that all installations be conducted by a qualified tradesperson. Please read and follow any additional installation guidelines provided with the products.

**Maintenance:** Normal preventative maintenance and cleaning will keep Frost products functioning properly and may extend normal product life. When refilling the soap reservoir, please remove the tank from the unit prior to refilling. We recommend that units be periodically rinsed out with warm water to prevent soap build up that may hinder the performance of the valve. Products should be wiped down with a damp soft cloth periodically. Approved stainless steel cleaner may be used to clean scuffs or fingerprints on stainless surfaces. Do not use harsh detergents or chemical cleaners. For stainless steel please do not spray with any product containing bleach, acids, or chlorides, which can be found in many cleaning products such as toilet bowl cleaners. Use of these cleaning solutions may cause discoloration and if used for prolonged periods of time they can eat away at points in the stainless steel. If discoloration occurs, the use of an approved stainless steel cleaner and a firmer scrub pad, such as a Scotch Brite Pad #7447, may remove the markings. Wipe away any debris from the area and gently rub with the pad. Then spray the area with a stainless steel cleaner/polish and rinse and dry. Always wipe with the grain direction for stainless steel products. If a cleaning agent has begun to eat away at the steel on a unit then the unit will likely need to be replaced. The stainless steel that Frost Products uses is of high quality and stainless steel is resistant to rust. However, discoloration that appears to be rust can be caused by cleaning solutions and soaps mentioned above. It is important to discontinue use of any cleaning agent or soap if discoloration begins to occur. Clean off the discoloration as quickly as possible to avoid any permanent damage to the unit. Maintenance staff should be taught how to recognize the signs that they are not using the appropriate cleaning products and how to correctly maintain stainless steel items.

**Warranty:** If any product or part proves to be defective within 12 months from date of shipment from the factory it will be repaired or replaced without any charge including freight costs when authorized. Costs resulting from the installation or removal of defective products are not covered under this warranty. Discoloration to stainless steel parts resulting from exposure to harsh environmental and / or chemicals are not considered to be defects in workmanship or material and are not covered under warranty.