



Specification Information

Product Code: 641

Product Name: Surface Mounted Feminine Product Disposal

Individual Carton UPC: 624622641009

Individual Carton Shipping Dimensions: 30.5cm W x 40.6cm H x 12.7cm D (12" W x 16" H x 5" D)

Individual Carton Shipping Weight: 3.1kg (7 lbs)

Site Location: Frost's 641 surface mounted feminine product disposal is practical, durable, and easy to maintain. This dispenser is a large capacity disposal unit designed for use in standard partition stalls. Its tilt open design makes it easy to service in confined spaces. Typically, these units are used in schools, malls, hospitals, office buildings, recreational facilities, and other commercial properties. The ease of use, durable construction, and low maintenance of this product make it a popular choice.

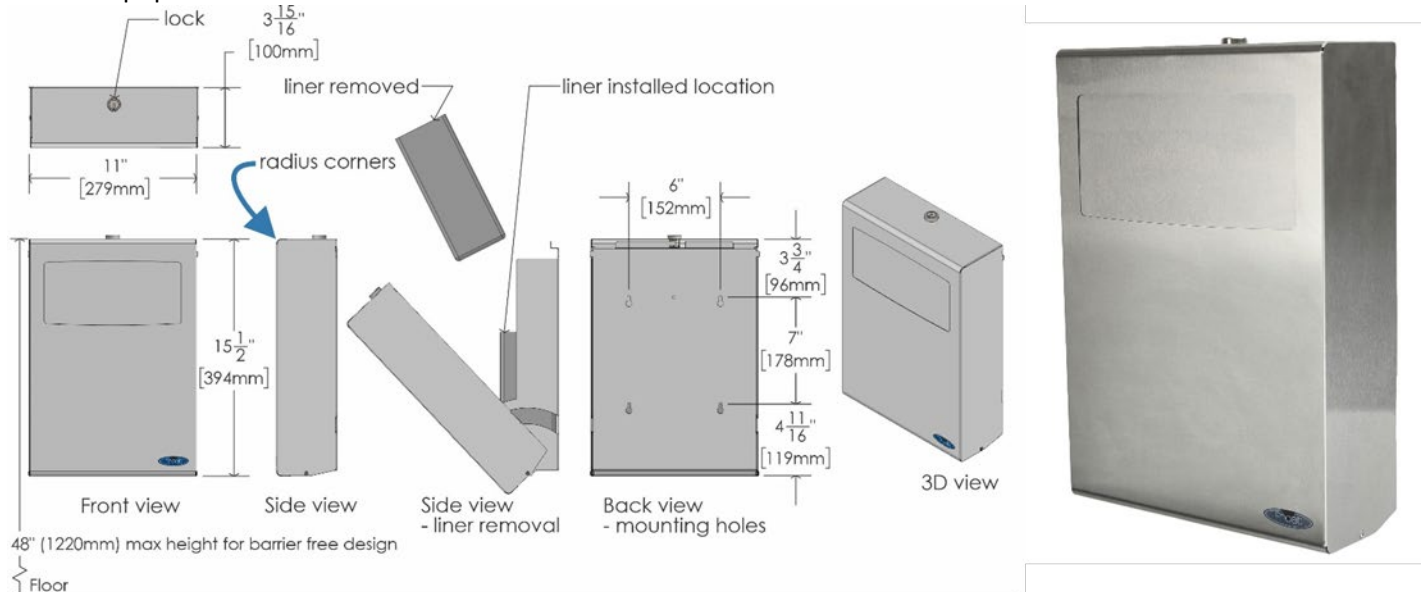

Features:

- Canadian made with 22 gauge stainless steel
- Removable leak proof plastic waste bin for easy maintenance
- Secured with a keyed tumbler lock and has a self-closing door
- Comes with English/French labels
- Full length stainless steel piano hinges on door

Capacity:

- 1 imp. gallon, 1.3 US gallons (5 litres)

Materials:

- All welded stainless steel construction, 22 gauge, type 430 No. 4 brushed finish

Product Dimensions:

- 27.9cm W x 39.4 cm H x 9.9cm D (11" W x 15.5" H x 3.9" D)

Product Weight:

- 3.1kg (7 lbs)

Frost Products Ltd

5276 John Lucas Drive
Burlington, ON, Canada, L7L5Z9

(905) 332-5700
1-800 667-5094

info@frostproductsltd.com
www.Frostproductsltd.com



Specification Information

Installation Guidelines: Use above drawing or unit as a template for mounting hole locations. For barrier free mounting ensure that top of unit does not exceed 120 cm (48") above floor level. Use the appropriate screws, anchors, and tools for installation. Please note that it is recommended that all installations be conducted by a qualified tradesperson. Failure to do so may result in serious injury. Please read and follow any additional installation guidelines provided with the products.

Maintenance: Normal preventative maintenance and cleaning will keep Frost products functioning properly and may extend normal product life. Products should be wiped down with a damp soft cloth periodically. Approved stainless steel cleaner may be used to clean scuffs or fingerprints on stainless surfaces. Do not use harsh detergents or chemical cleaners. For general dirt and blemishes on painted steel or plastic use warm water and mild soap, or a general mild cleaning solution. When using any type of cleaning solution, spray onto a discrete area to test before full usage. After the cleaning agent is applied, wipe off with a clean soft cloth or sponge. For stainless steel please do not spray with any product containing bleach, acids, or chlorides, which can be found in many cleaning products such as toilet bowl cleaners. Use of these cleaning solutions may cause discolouration and if used for prolonged periods of time they can eat away at points in the stainless steel. If discolouration occurs, the use of an approved stainless steel cleaner and a firmer scrub pad, such as a Scotch Brite Pad #7447, may remove the markings. Wipe away any debris from the area and gently rub with the pad. Then spray the area with a stainless steel cleaner/polish and rinse and dry. Always wipe with the grain direction for stainless steel products. If a cleaning agent has begun to eat away at the steel on a unit then the unit will likely need to be replaced. The stainless steel that Frost Products uses is of high quality and stainless steel is resistant to rust. However, discolouration that appears to be rust can be caused by cleaning solutions and soaps mentioned above. It is important to discontinue use of any cleaning agent or soap if discolouration begins to occur. Clean off the discolouration as quickly as possible to avoid any permanent damage to the unit. Maintenance staff should be taught how to recognize the signs that they are not using the appropriate cleaning products and how to correctly maintain stainless steel items.

Warranty: If any product or part proves to be defective within 12 months from date of shipment from the factory it will be repaired or replaced without any charge including freight costs when authorized. Costs resulting from the installation or removal of defective products are not covered under this warranty. Discolouration to stainless steel parts resulting from exposure to harsh environmental and / or chemicals are not considered to be defects in workmanship or material and are not covered under warranty.