



# Specification Information

**Product Code:** 400-70A – recessed, 400-70B – semi recessed, 400-70C – surface mounted

**Product Name:** Stainless Steel Combination Hands Free Dispenser/Disposal

**Individual Carton UPC:** 400-70A – 624622400170, 400-70B – 624622400279, 400-70C – 624622400378

**Individual Carton Shipping Dimensions:** 38.1cm W x 147.3cm H x 23.5cm D (15" W x 58" H x 9.25" D)

**Individual Carton Shipping Weight:** 400-70A – 24.9kg (55 lbs), 400-70B – 28.1kg (62 lbs), 400-70C – 30.4kg (67 lbs)

**Site Location:** Frost code 400-70 stainless steel hands-free automatic combination dispenser/disposal is Frost's largest combination fixture. The extra depth of this unit make it ideal for high volume areas. The hands-free operation is perfect where hygiene is a major concern. Typically, these units are used in hospitals, schools/universities, restaurants, malls, office buildings, condominiums, fitness facilities, and recreation centres. The stainless steel construction, sleek appearance, and automatic operation of this unit make it a popular choice.

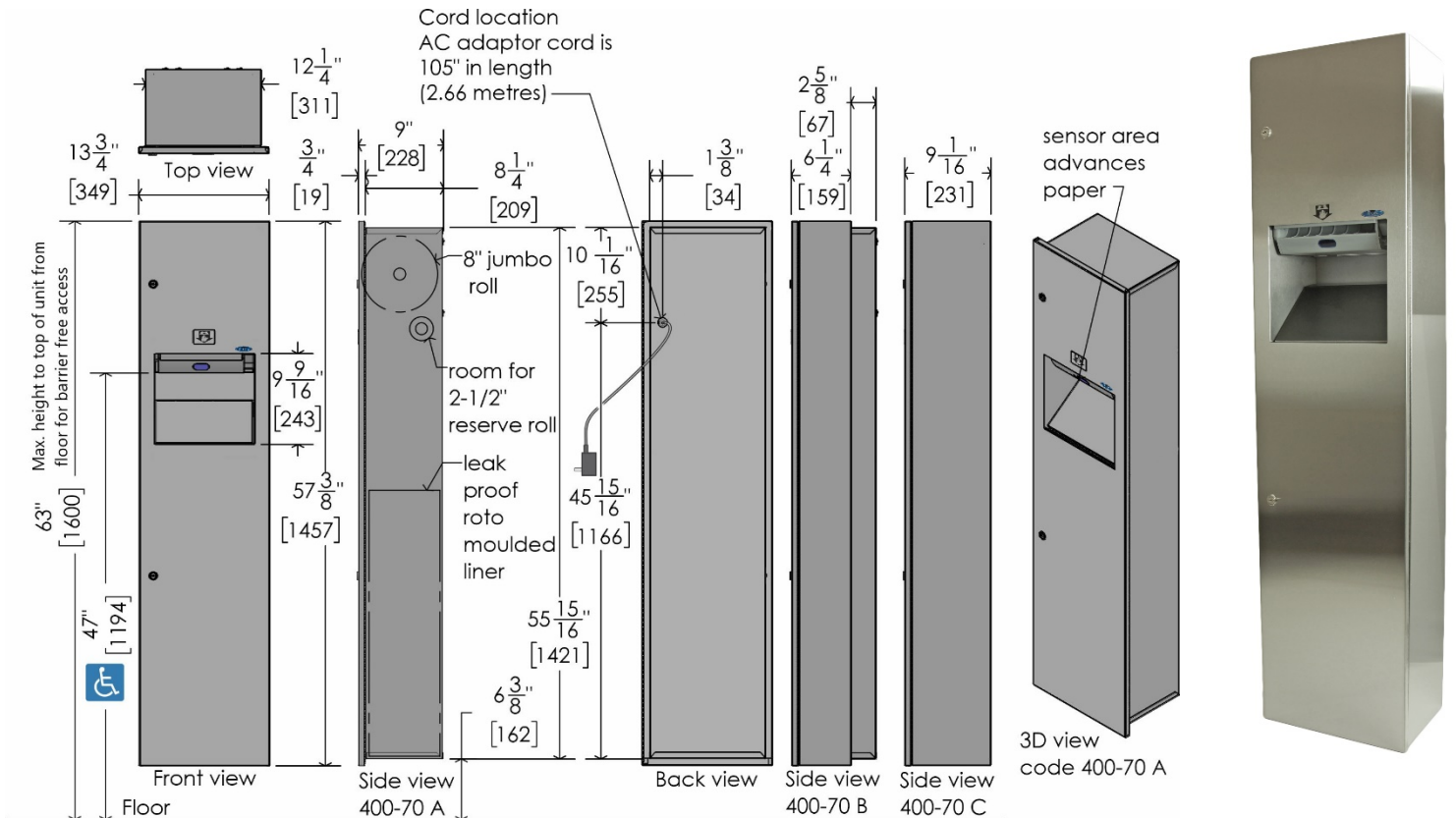

## Features:

- Hands-free automatic dispensing of paper
- Made with 18 & 20 gauge Canadian stainless steel
- Stainless steel (safety guarded) saw tooth cutting bar
- Secured with two tumbler keyed lock, keys provided
- All doors are hinged with full length stainless steel piano hinges
- Counterbalanced stainless steel door (20 gauge) provides maximum fire protection, mounted with full length piano hinge
- Removable leak proof roto moulded liner
- 9' AC adaptor included

Frost Products Ltd

5276 John Lucas Drive  
Burlington, ON, Canada, L7L5Z9

(905) 332-5700  
1-800 667-5094

info@frostproductsltd.com  
www.frostproductsltd.com



# Specification Information

**Dispensing:** Frost's 400-70 series is designed to dispense Jumbo 8" diameter (2.5" reserve roll) x 8" wide roll towels, core size of 1.375" and greater. The units are universal; meaning, the unit is non-proprietary and dispenses paper from standard commercial paper producers. This allows the end user to avoid getting locked into paper supply contracts and should save them money on their janitorial supplies. The unit is automatically operated when placing a hand within the large detection zone. An adjustable length of towel, between 6" and 9" (15.2 cm – 22.9cm) will then be dispensed. It can be refilled by unlocking the dispenser from the top. The lid will then swing down and new paper can be inserted. Please note that it is important to switch the dispenser off prior to installing new paper. The dispenser can be powered with the AC adaptor (included) or four "D" size alkaline batteries. Four alkaline batteries have been independently tested and found to provide 35,000 hand dries.

## Capacity:

- Removable liner with 47 litre capacity (12.4 US gal., 10.3 Imp. gal.)

## Materials:

- Body: 18 gauge stainless steel
- Door: 20 gauge stainless steel type 304 no. 4 brushed finish

## Product Dimensions:

- 34.9cm W x 145.7cm H 22.9cm D (13.75" W x 57.4" H x 9" D)

## Product Weight:

- 400-70A – 24.9kg (55 lbs), 400-70B – 28.1kg (62 lbs), 400-70C – 30.4kg (67 lbs)

**Installation Guidelines:** Provide 31.5cm wide x 143.2cm high x 21.6cm deep (12.375" W x 56.375" H x 8.5" D) wall opening. Using the appropriate tools for installation, drill mounting holes as required and attached the unit into desired surface. Collar is secured between recessed body flange and wall. For unrestricted access, height of top of unit to floor must not exceed 160.0 cm (63"). Please note that it is recommended that all installations be conducted by a qualified tradesperson. Please read and follow any additional installation guidelines provided with the products. Failure to do so may result in serious injury or death.

**Maintenance:** Normal preventative maintenance and cleaning will keep Frost products functioning properly and may extend normal product life. Products should be wiped down with a damp soft cloth periodically. The internal mechanism should be checked periodically for paper debris. A build up of debris can put excess stress on the mechanism motor and could lead it to failure sooner than normal. Approved stainless steel cleaner may be used to clean scuffs or fingerprints on stainless surfaces. Do not use harsh detergents or chemical cleaners. For stainless steel please do not spray with any product containing bleach, acids, or chlorides, which can be found in many cleaning products such as toilet bowl cleaners. Use of these cleaning solutions may cause discolouration and if used for prolonged periods of time they can eat away at points in the stainless steel. If discolouration occurs, the use of an approved stainless steel cleaner and a firmer scrub pad, such as a Scotch Brite Pad #7447, may remove the markings. Wipe away any debris from the area and gently rub with the pad. Then spray the area with a stainless steel cleaner/polish and rinse and dry. Always wipe with the grain direction for stainless steel products. If a cleaning agent has begun to eat away at the steel on a unit then the unit will likely need to be replaced. The stainless steel that Frost Products uses is of high quality and stainless steel is resistant to rust. However, discolouration that appears to be rust can be caused by cleaning solutions and soaps mentioned above. It is important to discontinue use of any cleaning agent or soap if discolouration begins to occur. Clean off the discolouration as quickly as possible to avoid any permanent damage to the unit. Maintenance staff should

Frost Products Ltd

5276 John Lucas Drive  
Burlington, ON, Canada, L7L5Z9

(905) 332-5700  
1-800 667-5094

info@frostproductsltd.com  
www.frostproductsltd.com



## *Specification Information*

be taught how to recognize the signs that they are not using the appropriate cleaning products and how to correctly maintain stainless steel items.

**Warranty:** If any product or part proves to be defective within 12 months from date of shipment from the factory it will be repaired or replaced without any charge including freight costs when authorized. Costs resulting from the installation or removal of defective products are not covered under this warranty. Discolouration to stainless steel parts resulting from exposure to harsh environmental and / or chemicals are not considered to be defects in workmanship or material and are not covered under warranty.