



# Specification Information

**Product Code:** 2011

**Product Name:** Pet Waste Disposal

**Individual Carton UPC:** 624622201142

**Individual Carton Shipping Dimensions:** 30.5cm W x 14.0cm H x 55.9cm D (12" W x 5.5" H x 22" D)

**Individual Carton Shipping Weight:** 4.3 kg (9.5 lbs)

**Site Location:** The 2011 pet waste bag disposal is perfect for any area with high traffic pet ownership. These disposals are designed for outdoor use in and around public parks, condominiums, residential paths, schools/universities, and common courtyard areas.

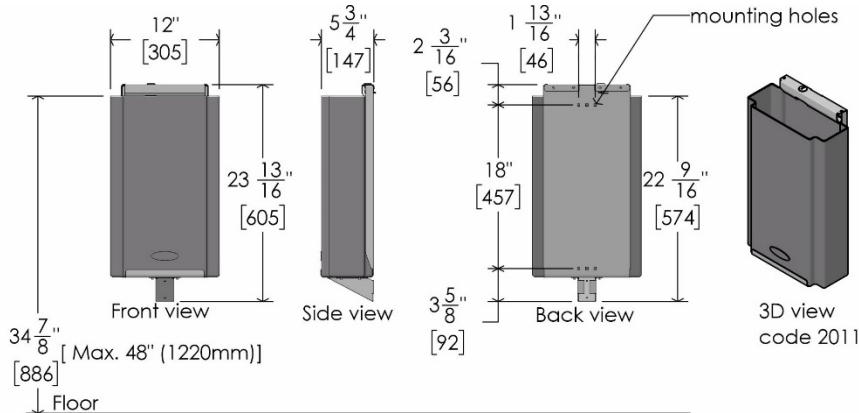

## Features:

- Modern professional appearance
- Canadian made
- Can be mounted to Frost code 909-100 pedestal or to standard square perforated sign post tubing
- Easy to install and maintain

**Characteristics:** The 2011 pet waste disposal is designed for use with Frost's pet waste station. The disposal bin is made from rugged rotationally moulded polyethylene that is 100% recycled. The disposal locks to the pedestal (sold separately, code 909-100) by the 18 gauge steel bracket (included), which is finished with grey rust proof powder coated paint. A locking mechanism keeps the waste receptacle securely in place and allows for easy removal during maintenance. The disposal includes drainage holes to keep the unit from retaining water during rainy periods. The capacity is 18.75 litres (4.1 imp gallons/5.4 US gallons). This disposal can be mounted to Frost code 909-100 pedestal or to standard square perforated sign post tubing.

## Capacity:

- 18.75 litres (4.1 imp gal, 5.4 US gal)

## Materials:

- Bracket: 18 gauge steel with RAL super durable TGIC-free polyester powder coating which provides a rust proof finish. Tested to survive harsh summer and winter weather.
- Disposal: 100% recycled polyethylene, black finish.

## Product Dimensions:

- 30.5cm W x 53.3cm H x 14cm D (12" W x 21" H x 5.5" D)

Frost Products Ltd

5276 John Lucas Drive  
Burlington, ON, Canada, L7L5Z9

(905) 332-5700  
1-800 667-5094

info@frostproductsltd.com  
www.frostproductsltd.com



## Specification Information

### Product Weight:

- 4.2 kg (9 lbs)

**Installation:** The unit is able to be installed on the Frost 909-100 mounting pedestal, or on standard square perforated sign post tubing (2" x 2"). Secure mounting bracket to pedestal or tubing using bolts (4), braces (2), and nuts (4) provided. Make sure the bracket is in the unlocked position, then slide the black disposal into the top of the bracket first. The bottom of the disposal will then slide into the bracket and lock into place once the key is turned. The disposal comes with mounting hardware to mount onto a Frost 909-100 post or perforated square post. This hardware includes four 1/4-20, 2" long stainless steel carrier bolts, four 1/4-20 stainless steel nylon lock nuts, and two bolt plates. You will require a 5/16" wrench/socket and #2 Robertson screw driver to install.

### Maintenance:

Normal preventative maintenance and cleaning will keep Frost products functioning properly and may extend normal product life. Products should be wiped down with a damp soft cloth periodically. Approved stainless steel cleaner may be used to clean scuffs or fingerprints on stainless surfaces. Do not use harsh detergents or chemical cleaners. For general dirt and blemishes on painted steel or plastic use warm water and mild soap, or a general mild cleaning solution. When using any type of cleaning solution, spray onto a discrete area to test before full usage. After the cleaning agent is applied, wipe off with a clean soft cloth or sponge.

### Warranty:

If any product or part proves to be defective within 12 months from date of shipment from the factory it will be repaired or replaced without any charge including freight costs when authorized. Costs resulting from the installation or removal of defective products are not covered under this warranty. Discolouration to stainless steel parts resulting from exposure to harsh environmental and / or chemicals are not considered to be defects in workmanship or material and are not covered under warranty.