



Specification Information

Product Code: 2010

Product Name: Pet Waste Bag Dispenser

Individual Carton UPC: 624622201043

Individual Carton Shipping Dimensions: 25.4cm W x 10.2cm H x 27.9cm D (10" W x 4" H x 11" D)

Individual Carton Shipping Weight: 2.3 kg (5 lbs)

Site Location: The 2010 pet waste bag dispenser is perfect for any area with high traffic pet ownership. These dispensers are designed for outdoor use in and around public parks, condominiums, residential paths, schools/universities, and common courtyard areas.

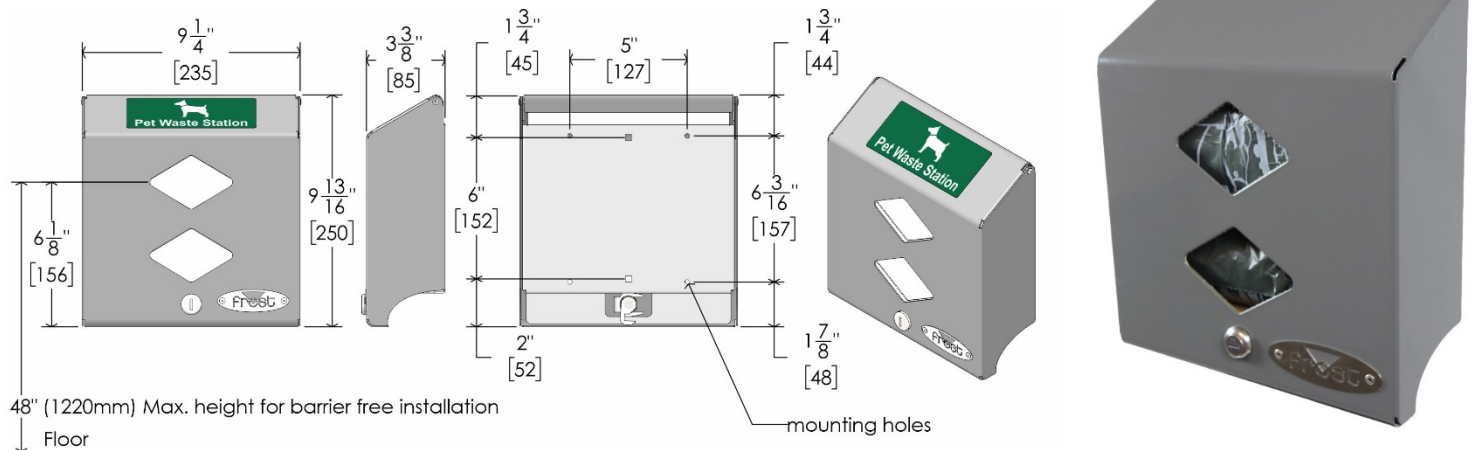

Features:

- Modern professional appearance
- Canadian made with heavy gauge steel
- Holds two boxes of pet waste bags
- Can be mounted to Frost code 909-100 pedestal, to a wall, or even to standard square perforated sign post tubing

Characteristics: The 2010 pet waste bag dispenser is made of heavy duty 18 gauge steel and finished with grey powder coated rust proof paint. The dispenser comes with a keyed tumbler lock to reduce pilferage and vandalism. The dispenser holds two boxes of pet waste disposable bags, each box holds 200 bags. Disposable bags are sold separately under Frost code 2012. This dispenser can be mounted to Frost code 909-100 pedestal, to a wall, or even to standard square perforated sign post tubing. The dispenser comes with a label reading "Pet Waste Station" which can be applied to the top of the dispenser if the end user wishes to do so. This label is shown in the product images.

Capacity:

- The dispenser holds two boxes of disposable bags. Each box holds 200 bags. Total capacity is 400 bags

Materials:

- 18 gauge steel with RAL super durable TGIC-free polyester powder coating which provides a rust resistant finish. Tested to survive harsh summer and winter weather.
- Frost uses Super Durable TGCI-Free Powder Coat paint on all their site furnishings products. This type of powder coating is designed for superior weatherability compared to standard TGIC polyester powder coatings. This type of paint is designed to meet the AAMA (American Architectural Manufacturers Association) standard 2603. It

Frost Products Ltd

5276 John Lucas Drive
Burlington, ON, Canada, L7L5Z9

(905) 332-5700
1-800 667-5094

info@frostproductsltd.com
www.frostproductsltd.com



Specification Information

provides excellent exterior color and gloss retention, superior over bake resistance, and good chemical resistance. The paint is designed to withstand 1500 hours of salt spray testing and 1 year of outdoor exposure in extreme conditions.

Product Dimensions:

- 23.5cm W x 24.9cm H x 8.6cm D (9.25" W x 9.8" H x 3.4" D)

Product Weight:

- 2 kg (4.5 lbs)

Installation: For unrestricted access, bottom of unit to floor must not exceed 48" (121.9cm). The unit is able to be installed on an exterior building wall, on the Frost 909-100 mounting pedestal, or on a standard square perforated sign post tubing (2"x 2"). The dispenser comes with mounting hardware to mount onto a Frost 909-100 post. This hardware includes two ¼-20, 2" long stainless steel carrier bolts and two ¼-20 stainless steel nylon lock nuts. You will require a 5/16" wrench/socket and #2 Robertson screw driver to install.

Maintenance:

Normal preventative maintenance and cleaning will keep Frost products functioning properly and may extend normal product life. Products should be wiped down with a damp soft cloth periodically. Approved stainless steel cleaner may be used to clean scuffs or fingerprints on stainless surfaces. Do not use harsh detergents or chemical cleaners. For general dirt and blemishes on painted steel or plastic use warm water and mild soap, or a general mild cleaning solution. When using any type of cleaning solution, spray onto a discrete area to test before full usage. After the cleaning agent is applied, wipe off with a clean soft cloth or sponge.

Warranty:

If any product or part proves to be defective within 12 months from date of shipment from the factory it will be repaired or replaced without any charge including freight costs when authorized. Costs resulting from the installation or removal of defective products are not covered under this warranty. Discolouration to stainless steel parts resulting from exposure to harsh environmental and / or chemicals are not considered to be defects in workmanship or material and are not covered under warranty.