



Specification Information

Product Code: 180

Product Name: Facial Tissue Dispenser

Individual Carton UPC: 624622180015

Individual Carton Shipping Dimensions: 27.9cm W x 16.5cm H x 8.9cm D (11" W x 6.5" H x 3.5" D)

Individual Carton Shipping Weight: 0.9 kg (2 lbs)

Site Location: Frost's 180 facial tissue dispenser offers a durable and practical solution for any site location. Typically, this dispenser is used in schools/universities, restaurants, malls, office buildings, condominiums, fitness facilities, and recreation centres. The product's sleek appearance, durable construction and ease of use make this an ideal dispenser for end users.

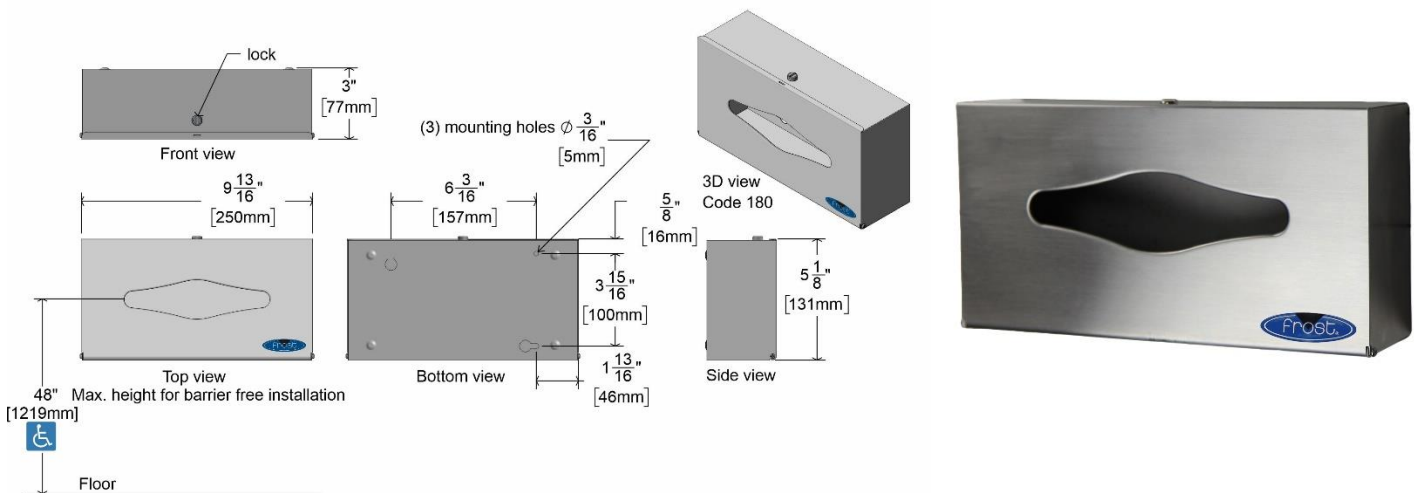

Features:

- Straightforward design makes this product user friendly and also reduces the risk of product malfunction
- Non-proprietary dispenser which can lead to cost savings for end users and property managers
- Front loading for easy service and maintenance
- Front secured with keyed lock to prevent theft

Dispensing: This product dispenses tissues manually through the center of the unit. The dispenser is also universal; meaning, the unit is non-proprietary and dispenses paper from standard commercial paper producers. This allows the end user to avoid getting locked into paper supply contracts and should save them money on their janitorial supplies. To load this product, first use the key to unlock the unit. The unit can be unlocked by applying pressure with the key in the open slot located on the top of the unit. Once unlocked, replenish with the desired tissues and snap the front of the unit back into place.

Capacity:

- This dispenser accepts all standard facial tissues

Materials:

- Made from 22 gauge type 201 stainless steel
- Brushed stainless steel finish

Frost Products Ltd

5276 John Lucas Drive
Burlington, ON, Canada, L7L5Z9

(905) 332-5700
1-800 667-5094

info@frostproductsltd.com
www.frostproductsltd.com



Specification Information

Product Dimensions:

- 24.9cm W x 13.0cm H x 7.6cm D (9.8" W x 5.1" H x 3.0" D)

Product Weight:

- 0.8 kg (1.75 lbs)

Installation Guidelines: This dispenser comes with four standard combination screws, anchors, and two keys. Mark mounting holes against the mounting surface using a pencil and level. Use a screwdriver or power drill to drill screws in the desired mounting surface and attach the dispenser. Please note that it is recommended that all installations be conducted by a qualified tradesperson. Please read and follow any additional installation guidelines provided with the products.

Maintenance:

Normal preventative maintenance and cleaning will keep Frost products functioning properly and may extend normal product life. Products should be wiped down with a damp soft cloth periodically. Approved stainless steel cleaner may be used to clean scuffs or fingerprints on stainless surfaces. Do not use harsh detergents or chemical cleaners. For general dirt and blemishes on painted steel or plastic use warm water and mild soap, or a general mild cleaning solution. When using any type of cleaning solution, spray onto a discrete area to test before full usage. After the cleaning agent is applied, wipe off with a clean soft cloth or sponge.

Warranty:

If any product or part proves to be defective within 12 months from date of shipment from the factory it will be repaired or replaced without any charge including freight costs when authorized. Costs resulting from the installation or removal of defective products are not covered under this warranty. Discolouration to stainless steel parts resulting from exposure to harsh environmental and / or chemicals are not considered to be defects in workmanship or material and are not covered under warranty.