



Specification Information

Product Code: 165-DP

Product Name: Recessed Multi-roll Toilet Tissue Dispenser, Reserve Roll

Individual Carton UPC: 624622165208

Individual Carton Shipping Dimensions: 38.1cm H x 36.8cm W x 27.9cm D (15" H x 14" W x 11" D)

Individual Carton Shipping Weight: 5.9kg (13 lbs)

Site Location: Frost's 165-DP recessed multi-roll toilet tissue dispenser is a high quality, durable and practical product. Typically, the dispenser is used in schools/universities, restaurants, malls, office buildings, condominiums, fitness facilities, and recreation centres. The product's ease of use, low maintenance and compact construction make this an ideal dispenser for areas trying to maximize space.

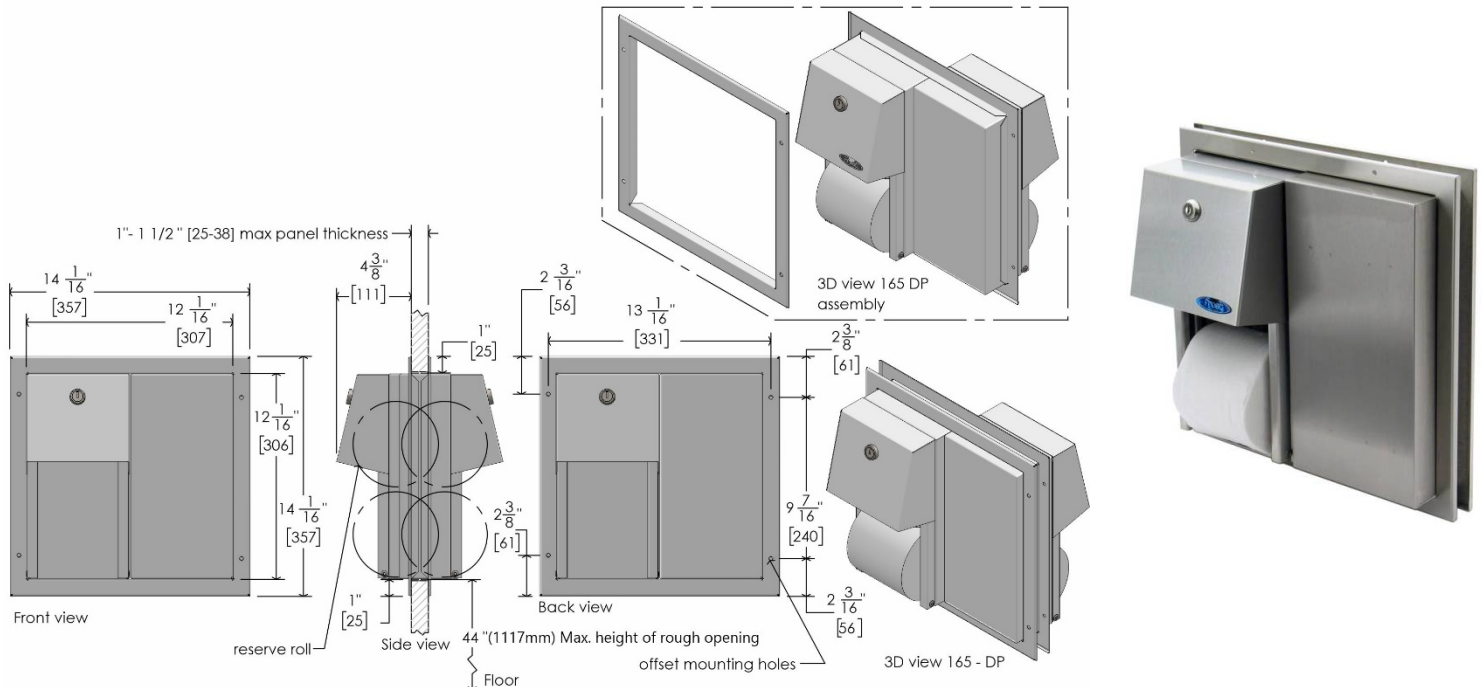

Features:

- Straightforward design makes this product user friendly and also reduces the risk of product malfunction
- Non-proprietary dispenser which can lead to cost savings for end users and property managers
- Comes with keyed tumbler lock to reduce pilferage and vandalism
- Front loading for easy service and maintenance
- Reserve roll only dispenses second roll after the first roll is empty, thus reducing the chance of having two half-empty rolls

Dispensing: This product dispenses toilet paper manually. This dispenser is also non-proprietary; meaning, this product can dispense paper from any standard commercial paper producer. This allows the end user to avoid getting locked into paper supply contracts and should save them money on their janitorial supplies. To load this product, unlock and lift the front cover. Slide the spindle out of the unit, place a standard toilet paper roll on the spindle, return spindle to original position. Replace the lid and lock.

Capacity:

- Frost code 165-DP will dispense all standard toilet tissue rolls including 10.7cm x 11.4cm (4" x 4½"), 500 sheet rolls

Frost Products Ltd

5276 John Lucas Drive
Burlington, ON, Canada, L7L5Z9

(905) 332-5700
1-800 667-5094

info@frostproductsltd.com
www.frostproductsltd.com



Specification Information

- Capacity of four rolls per unit

Materials:

- Recessed frame is one piece all stainless steel welded construction of 22 gauge SS

Product Dimensions:

- 35.8cm H x 35.8cm W x 26.0cm D (14.1" H x 14.1" W x 10.25" D)

Product Weight:

- 5.7kg (12.5 lbs)

Installation Guidelines:

For unrestricted access, roll should be mounted at least 48.3cm (19") above the finished floor. This dispenser comes with four standard combination style screws and two keys. Provide rough opening 31.8cm H x 31.4cm W (12½" H x 12⅜" W). Attach frames to partition, when secure slip toilet tissue unit through frame and secure to back of frame with mounting screws provided. Use a screwdriver or power drill to drill screws in the partition and attach the dispenser. Please note that it is recommended that all installations be conducted by a qualified tradesperson. Please read and follow any additional installation guidelines provided with the products.

Maintenance: Normal preventative maintenance and cleaning will keep Frost products functioning properly and may extend normal product life. Products should be wiped down with a damp soft cloth periodically. Approved stainless steel cleaner may be used to clean scuffs or fingerprints on stainless surfaces. Do not use harsh detergents or chemical cleaners. For stainless steel please do not spray with any product containing bleach, acids, or chlorides, which can be found in many cleaning products such as toilet bowl cleaners. Use of these cleaning solutions may cause discoloration and if used for prolonged periods of time they can eat away at points in the stainless steel. If discoloration occurs, the use of an approved stainless steel cleaner and a firmer scrub pad, such as a Scotch Brite Pad #7447, may remove the markings. Wipe away any debris from the area and gently rub with the pad. Then spray the area with a stainless steel cleaner/polish and rinse and dry. Always wipe with the grain direction for stainless steel products. If a cleaning agent has begun to eat away at the steel on a unit then the unit will likely need to be replaced. The stainless steel that Frost Products uses is of high quality and stainless steel is resistant to rust. However, discoloration that appears to be rust can be caused by cleaning solutions and soaps mentioned above. It is important to discontinue use of any cleaning agent or soap if discoloration begins to occur. Clean off the discoloration as quickly as possible to avoid any permanent damage to the unit. Maintenance staff should be taught how to recognize the signs that they are not using the appropriate cleaning products and how to correctly maintain stainless steel items.

Warranty: If any product or part proves to be defective within 12 months from date of shipment from the factory it will be repaired or replaced without any charge including freight costs when authorized. Costs resulting from the installation or removal of defective products are not covered under this warranty. Discoloration to stainless steel parts resulting from exposure to harsh environmental and / or chemicals are not considered to be defects in workmanship or material and are not covered under warranty.