



Specification Information

Product Code: 1125

Product Name: Baby Change Table

Individual Carton UPC: 624622112509

Individual Carton Shipping Dimensions: 91.4cm W x 45.7cm D x 10.2cm H (36" W x 18" D x 4"H)

Individual Carton Shipping Weight: 8.2kg (18.0 lbs)

Site Location: Frost's 1125 Kidz Zone baby change table offers a quality and reliable product at an affordable price point. Typically, this product is used in Restaurants, Airports, Service Stations, Retail locations, and Daycares/Schools. The product's ease of use, maintenance, and price point make it a popular choice.

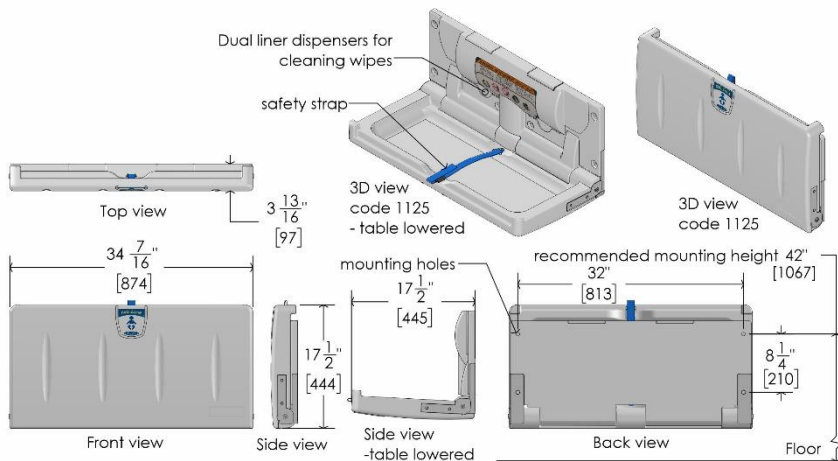

Features:

- Easy to clean and maintain
- FDA approved, bacterial resistant, high-density polyethylene, light grey colour
- Dual liner dispensers for cleaning wipes
- ADA, ANSI, and ASTM F2285 compliant
- Easy to clean child protection strap included
- Pneumatic gas shock mechanism to ensure smooth opening and closing
- Convenient bag hooks located at either end of the table

Materials:

- Body: FDA approved high density polyethylene, light grey colour
- Safety Strap: Composite material
- Hinges: Steel on Steel and pneumatic gas

Capacity:

- Meets or exceeds ASTM F2285 requirements for weight and has a static load capacity of 250lbs (115kg). Intended for children 3.5 years old and under and weighing less than 50 lbs.

Compliance: Frost code 1125 is designed to be easy to use and operate while not sacrificing child safety. This product meets A.D.A. standards due to its slim profile of 10.2cm (4") when closed. The safety strap can also be operated by one

Frost Products Ltd

5276 John Lucas Drive
Burlington, ON, Canada, L7L5Z9

(905) 332-5700
1-800 667-5094

info@frostproductsltd.com
www.frostproductsltd.com



Specification Information

hand, meeting A.D.A. standards. The recommended mounting height for A.D.A. compliance is 107cm (42"). If mounted correctly the product is compliant to the following A.D.A. sections:

- 3 – Knee Clearance
- 2 – Maximum Protruding Objects
- 2 – Forward Reach
- 3 – Side Reach
- 4 – Operation
- 3 – Work Surface

This unit also has ANSI Z535.2 and Z535.4 complaint safety labels. Warning labels in English, French, and Spanish. The product meets or exceeds ASTM F2285 safety specifications for weight for commercial baby changing stations. The product meets or exceeds ASTM G21 Anti-Bacterial with no measurable bacterial growth. The product meets or exceeds ASTM G22 Anti-Fungal with no measurable fungal growth. Finally, the 1125 change station is compliant to applicable sections of CPSIA.

Product Dimensions:

- Door Closed: 87.4cm W x 9.6cm D x 44.5cm H (34.4" W x 3.8" D x 17.5"H)
- Door Open: 87.4cm W x 44.5cm D x 44.5cm H (34.4" W x 17.5" D x 17.5"H)

Product Weight:

- 8.0 kg (15.0 lbs)

Installation: For complete installation instructions please see specification page or the instructions within the packaging of your unit. For unrestricted access, bottom of unit to floor must be between 38.1cm and 121.9cm (15" to 48"). Unit comes with four 3" wood screws, four 3/4" finishing washers, two 3" machine screws, four 3/4" flat washers, two toggle anchors, six 1 1/4" caps, and one door/wall plate. Warning: a stud must be located and used for at least one side of the changing station. The change station is no stronger than the anchors or walls to which they are attached and, therefore, must be firmly secured in order to support the weight they are intended to support. We recommend installation be completed by a qualified tradesperson.

Maintenance: Normal preventative maintenance and cleaning will keep Frost products functioning properly and may extend normal product life. Products should be wiped down with a damp soft cloth periodically. Approved stainless steel cleaner may be used to clean scuffs or fingerprints on stainless surfaces. Do not use harsh detergents or chemical cleaners. For general dirt and blemishes on painted steel or plastic use warm water and mild soap, or a general mild cleaning solution. When using any type of cleaning solution, spray onto a discrete area to test before full usage. After the cleaning agent is applied, wipe off with a clean soft cloth or sponge. Check all hardware and components monthly or as required by site usage to ensure hardware is tight and there are no missing or damaged pieces. For replacement parts please contact 1 (800) 667-5094. Do not use substitute parts.

Safety Warning: The baby changing station must be installed by qualified trades persons. Installers must consult and comply with local building codes. Mounting hardware and other systems to be determined by contractor and installer pending specific structure, design, and conditions. All installations must be fully inspected and approved by property owners and maintenance personnel prior to product being put into use. Failure to comply to proper installation procedure will void warranty and may result in malfunctioning or injury.

Frost Products Ltd

5276 John Lucas Drive
Burlington, ON, Canada, L7L5Z9

(905) 332-5700
1-800 667-5094

info@frostproductsltd.com
www.frostproductsltd.com



Specification Information

Warranty: If any product or part proves to be defective within 12 months from date of shipment from the factory it will be repaired or replaced without any charge including freight costs when authorized. Costs resulting from the installation or removal of defective products are not covered under this warranty. Discolouration to stainless steel parts resulting from exposure to harsh environmental and / or chemicals are not considered to be defects in workmanship or material and are not covered under warranty.